



Personal Daqs™

USB Data Acquisition Modules Models /55, & /56



Features

- Multi-function data acquisition modules attach to PCs via Universal Serial Bus (USB 1.0 & 2.0 compatible)
- Ultra low-power design requires no external power or batteries
- Can be located up to 5 meters (16.4 feet) from the PC
- High-resolution, 22-bit A/D converter offers reading rates from 1 to 80 Hz
- Built-in cold-junction compensation for direct thermocouple measurements
- Frequency/pulse, or duty-cycle measurements up to 1 MHz
- Convenient removable screw-terminal signal connections
- 500V optical isolation from PC for safe and noise-free measurements
- Programmable inputs from ± 31 mV to ± 20 V full scale
- Digital I/O lines with open collector output for direct drive applications
- Expandable up to 80 channels of analog and digital I/O
- Up to 100 Personal Daq modules can be attached to one PC using USB hubs, for a total capacity of 8,000 channels
- Digital calibration—no potentiometers or adjustments required

Software

- Personal DaqView™, spreadsheet-style software for *Out-of-the-Box™* setup, acquisition, & real-time display
- eZ-PostView™, for post-acquisition data viewing
- Support for Visual Basic®, C/C++, LabVIEW®, and DASyLab®

Designed for high accuracy and resolution, the 22-bit Personal Daq™ data acquisition systems directly measure multiple channels of voltage, thermocouples, pulse, frequency, and digital I/O. A single cable to the PC provides high-speed communication *and* power to the Personal Daq. No additional batteries or power supplies are required in most applications*.

The Personal Daq modules are a family of low-cost, USB-based products from IOtech. Because of the strict power limitations of the USB, the modules incorporate special



power-management circuitry to ensure adherence to USB specifications.

The Personal Daqs avoid many of the limitations of PC-Card (PCMCIA) data acquisition devices. The Personal Daq/55™ data acquisition system offers 10 single-ended or 5 differential analog (up to ± 20 V full scale) or thermocouple input channels, 16 programmable ranges, 500V optical isolation, eight digital I/O lines, and two frequency/pulse/duty-cycle channels. The Personal Daq/56™ offers twice the I/O capacity in the same size package.

To simplify attachment of signals and transducers, the Personal Daq modules feature convenient, removable screw-terminal input connections.



The compact Personal Daq is ideal for portable data acquisition applications

* In rare instances an external power source is required when PC-supplied power is inadequate



Personal Daqs™

General Information



Personal Daq with removable terminal block

Software*

The Personal Daqs are supplied with Personal DaqView, IOtech's Windows®-based data logging application that allows you to set up your acquisition applications and save acquired data directly to disk. The Personal Daqs are also shipped with eZ-PostView™, a post-acquisition application that permits you to display acquired data previously saved to a file. Drivers for Visual Basic®, and C/C++ for Windows® 98 and higher are also included. In addition, drivers are available for icon-based software packages, such as LabVIEW®, and DASyLab®.

* It is recommended that Windows® 98 and higher be used as the operating system; in most cases, Windows® 95 version 4.00.95B or later (with the USB supplement), will provide adequate support; Windows® NT does not provide USB support therefore the Personal Daq cannot be used with a Windows NT operating system.

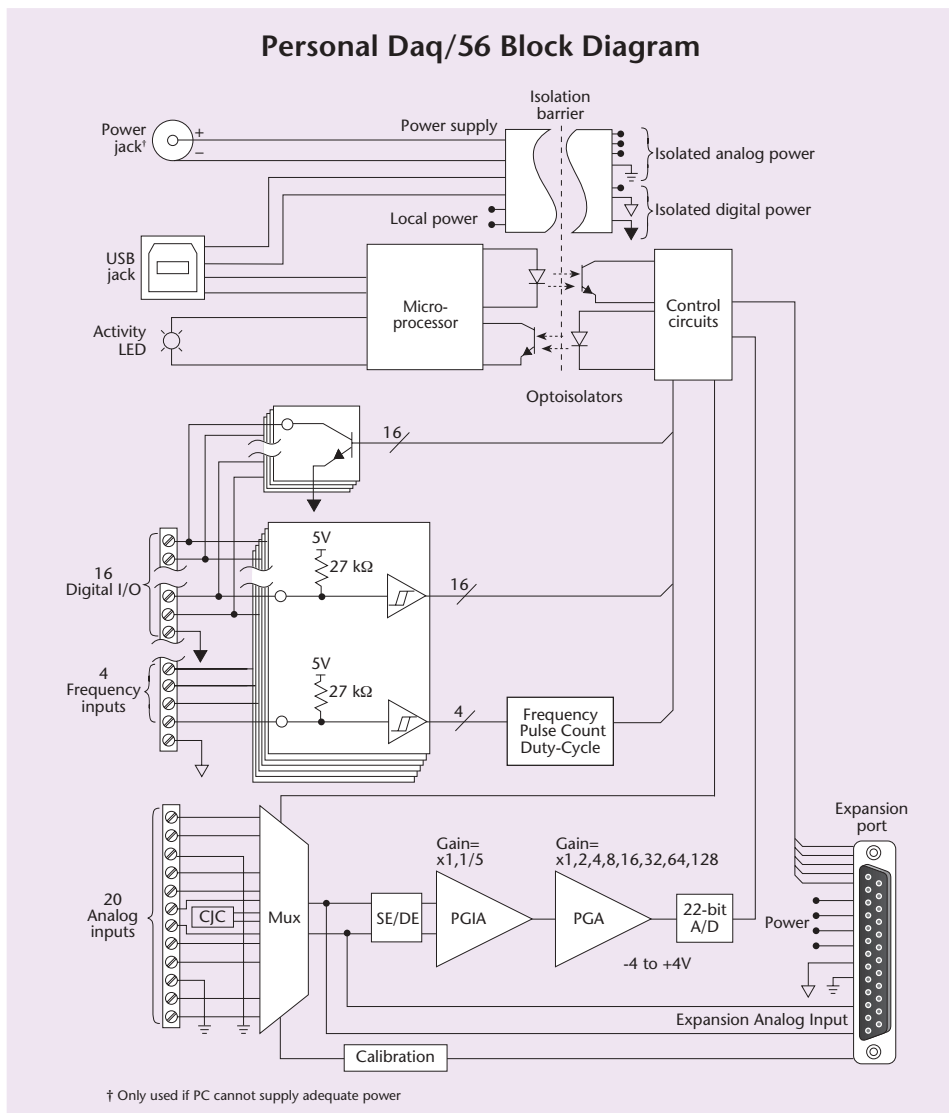

† Only used if PC cannot supply adequate power

About USB

The Universal Serial Bus (USB) is a standard for connecting PCs to peripheral devices such as printers, monitors and modems. USB offers several advantages over conventional serial and parallel connections, including higher bandwidth (up to 12 Mbits/s) and the ability to provide power to the peripheral device.

USB is ideal for data acquisition applications. Since USB connections supply power, only one cable is required to link the data acquisition device to the PC, which most likely has at least one USB port. In addition, the USB's high-speed data transfer (from the data acquisition device to the PC) allows for a real-time display of acquired data, while eliminating the need for expensive memory in the acquisition device.

With the backing of Intel®, Microsoft®, and hundreds of other computer-related companies, USB is a universal standard; in fact, all computers now have USB capability.



The CA-179-x USB cable



Personal Daqs™ Expansion

Personal Daq Expansion

Both the Personal Daq/55 and the Personal Daq/56 can be easily expanded with one of two available snap-on expansion modules, bringing the total capacity up to 60 analog or thermocouple channels, 32 digital I/O lines, and 4 frequency input channels. Furthermore, USB hubs can be used to create multi-unit systems containing up to 100 Personal Daq modules attached to a single PC. Using this strategy, a multi-unit Personal Daq system can provide up to 8,192 analog and digital I/O lines.

See the chart to the right for available channel capacity.



A Personal Daq and a PDQ module simply plug together for additional channel capacity

Personal Daq and Expansion System Channel Capacities			
Product or System	Volts/TC Inputs*	Digital I/O	Freq/Pulse Inputs
Personal Daq/55	5 DE, 10 SE	8	2
Personal Daq/56	10 DE, 20 SE	16	4
PDQ1 Expansion Module	10 DE, 20 SE	16	-
PDQ2 Expansion Module	20 DE, 40 SE	-	-
Personal Daq/55 + PDQ1	15 DE, 30 SE	24	2
Personal Daq/55 + PDQ2	25 DE, 50 SE	8	2
Personal Daq/56 + PDQ1	20 DE, 40 SE	32	4
Personal Daq/56 + PDQ2	30 DE, 60 SE	16	4

* TC inputs are differential only

PDQ10™ DIN-rail Mounting Adapter

The PDQ10 allows one Personal Daq or PDQ module to be DIN-rail mounted. The Personal Daq or PDQ module simply snaps into the PDQ10.



PDQ12™ USB Extender Cable

Each PDQ12 adds 16 ft. to the length of your USB cable. Up to five of these plug-and-play active cables can be cascaded, for a total cable length of 96 ft. (when added to a passive 16 ft. USB cable).



PDQ11™ 4-port Powered Hub

Add up to four USB devices to your system with this easy plug-and-play expansion hub. This hub provides full USB power to additional devices. Hubs can be cascaded for additional ports.



PDQ13™ PCI to Dual USB Card

The PDQ13 adds two USB ports to your desktop PC, and plugs into your PC's PCI slot.





Personal Daqs™

Example Systems

Example Systems

As a USB product, the Personal Daq data acquisition system can be located up to five meters (16.4 feet) from the PC, allowing it to reside close to the point of measurement for improved accuracy and reduced noise. If USB hubs or USB-powered extension cables are used as repeaters between USB cable segments, the Personal Daq can be located up to 30 meters (98.4 feet) from the PC.

Direct Connection to Computer USB Port(s)

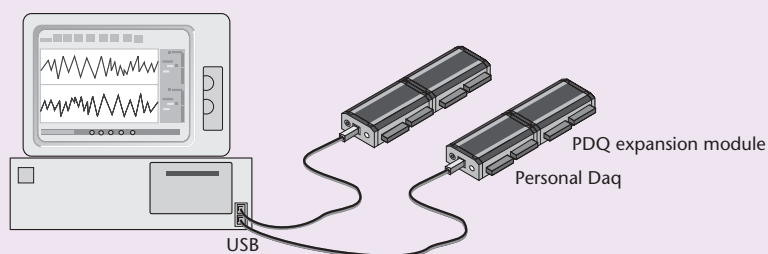

Two Personal Daqs (with optional PDQ modules) are connected by cable to each of the computer's USB ports, requiring no external power source

Connection to Powered USB-Hub

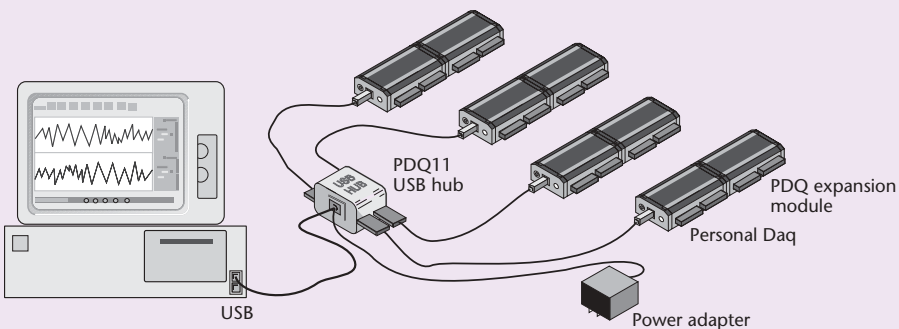

Four Personal Daqs (with optional PDQ modules) are connected to ports of a USB hub, requiring an external power source



Software Support

Included Software for Personal Daqs™

The Personal Daqs™ are supported by several levels of software support, allowing you to select the software environment that best fits your application and skill set.

On this page is a description of the software that is included with every Personal Daq. The next page is an overview of optional software available for the Personal Daqs.

Out-of-the-Box™ Personal DaqView™

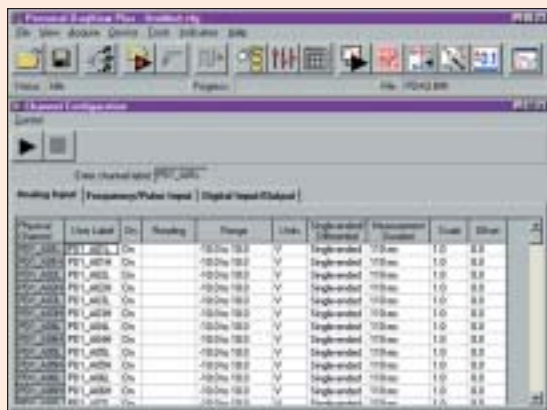

Personal DaqView™ graphical data acquisition and display software is included with all Personal Daq systems. Using Personal DaqView software's spreadsheet-style interface, you can easily set up your application and begin taking data within minutes of connecting your hardware, with no programming required.

eZ-PostView™

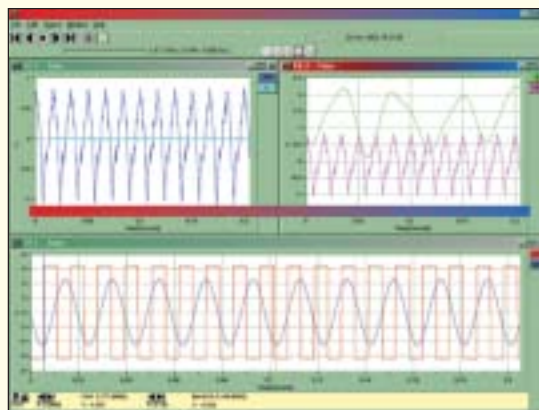

eZ-PostView™ is included with the Personal Daq, providing a simple method of graphically viewing acquired waveforms from the Personal Daq. Up to 8 windows can be displayed on one screen, with up to 16 channels overlaid on each window. eZ-PostView makes it simple to visually inspect acquired waveforms from multiple channels within seconds of acquiring the data.

DaqX Subroutine API Libraries

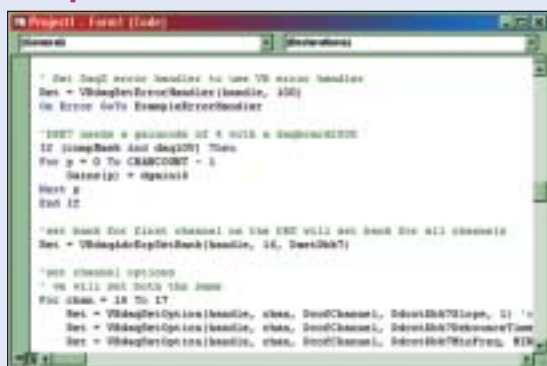

Personal Daqs are supplied with free DaqX Subroutine API Libraries providing complete support for all of the functionality available on each data acquisition device in Visual Basic®, and C/C++. Further, DaqX is supported under all versions of Windows®. Included with DaqX Subroutine API Libraries are over 100 example programs, and comprehensive API documentation is provided through an online programmers manual.

LabVIEW® Support

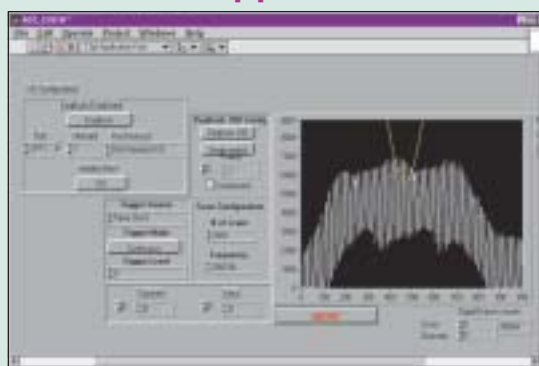

IOtech offers extensive LabVIEW® support for the Personal Daq, including expansion and signal conditioning modules. IOtech data acquisition VIs for LabVIEW are more than just simple hardware access VIs, they are complete with engineering data conversion, data display and logging capabilities.



Software Support

Optional Software for Personal Daqs™

Personal DaqView Plus™ & XL™

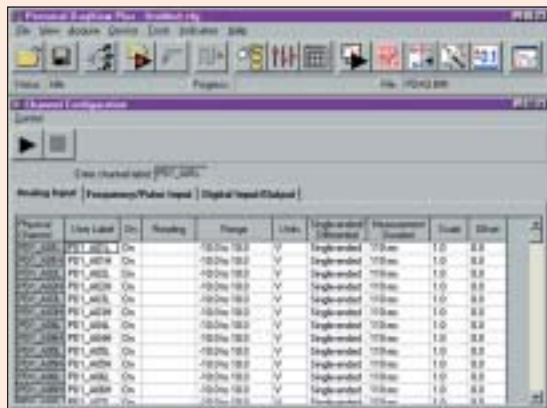

Optional Personal DaqView Plus™ provides advanced charting capabilities, including multiple traces per chart, multiple chart groups, and support for up to 100 Personal Daq devices attached to one PC. It allows display groups to be created for customized viewing and supports up to 100 Personal Daq devices. Optional Personal DaqViewXL™ allows Personal DaqView™ or Personal DaqViewXL Plus™ to seamlessly execute from within Microsoft® Excel's tool palette.

eZ-TimeView™

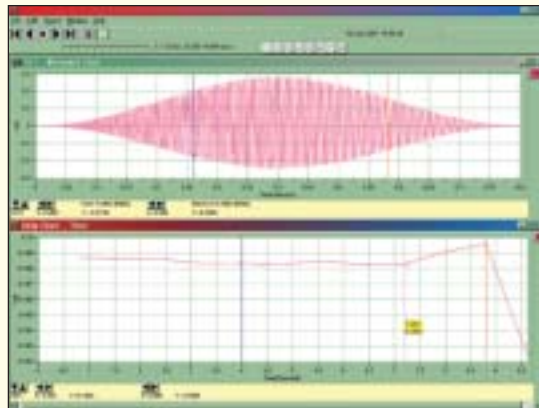

eZ-TimeView™ is a post-acquisition analysis package for data acquired from the Personal Daq. eZ-TimeView is targeted at time-domain analysis, including min/max, peak-peak, mean, RMS, plus a wide variety of plotting and waveform viewing capabilities.

DASYLab®

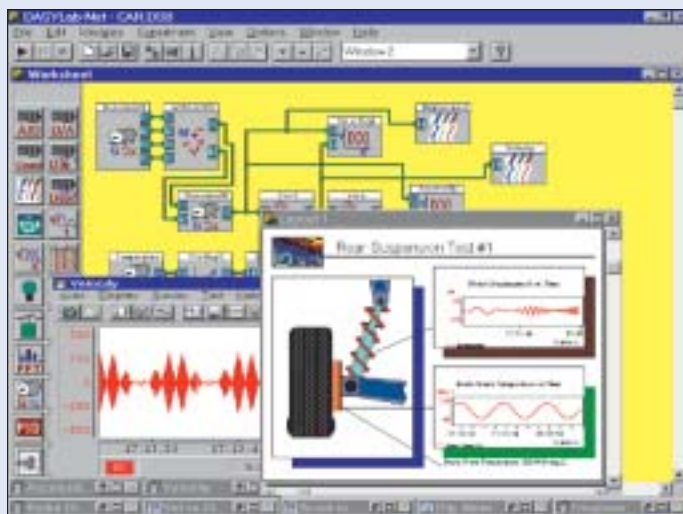

If your application requirements go beyond the scope of Personal DaqView™, DASYLab® software offers a greater degree of flexibility and customization. You can learn DASYLab in a matter of days, without the weeks of training required for some other icon-based application-development software.

IOtech offers a special version of DASYLab with the Personal Daq (Personal Daq/55/DL and Personal Daq/56/DL) for a special bundled price.



Personal DaqView™

Out-of-the-Box™ Software



Personal DaqView™, IOtech's included *Out-of-the-Box™* graphical data acquisition software, is an easy-to-use yet powerful application. It allows users to configure a test, and display or record data within minutes, without programming. Together

with included eZ-PostView™ post-acquisition viewer software, Personal DaqView offers the most functionality of any free software of its kind.



Personal DaqView lets the user:

- 1 Select one of any Personal Daqs connected to the system
- 2 Set up, configure and display analog, frequency, counter and digital I/O channels in real time
- 3 Easily and quickly configure acquisition parameters such as trigger events, stop events and acquisition scan rates
- 4 Acquire analog, frequency, and digital I/O channels to disk in real time
- 5 View real-time analog, frequency, and digital I/O using extensive charting and metering displays
- 6 View acquisition status at a glance, including triggered time/date, acquisition progress, as well as acquisition destination file

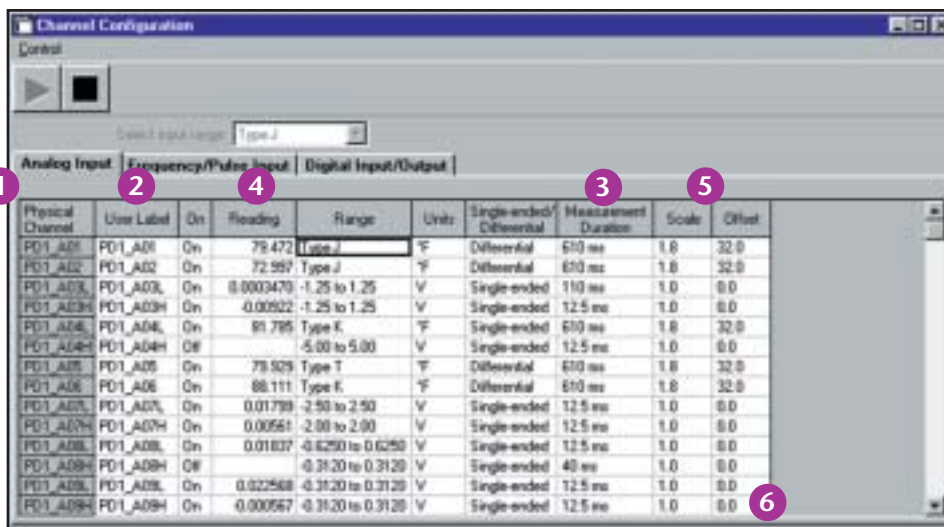

The Analog Input screen allows the user to:

- 1 Easily configure analog input channels such as voltage and temperature measurements
- 2 View channels through both a physical channel description or a user-defined channel description
- 3 Select the minimum measurement duration for a channel on a per-channel basis
- 4 Display real-time readings of active or enabled channels
- 5 Apply scale and offset for real-time $mX+b$ operation
- 6 Have the spreadsheet automatically "grow" as more channels are added to the system



Personal DaqView™

Out-of-the-Box™ Software

Custom Real-Time Displays

Personal DaqView allows the creation of customized real-time displays using built-in display options, including digital, dial meter, bar graph, and strip chart displays. No programming is required — simply point, click, and drag desired display options to create a custom screen.



Dial Meter

Personal DaqView allows up to 32 channels to be shown in a dial display format. Each dial indicates instantaneous levels, as well as peak hold and trends.

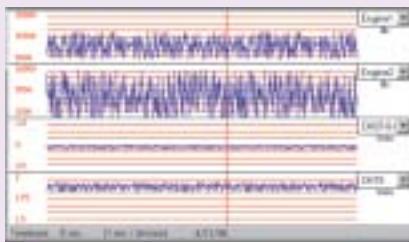

Strip Chart

Display up to 16 smooth-scrolling strip charts of data, all of which scroll at the same rate, and define a full-scale range for each individual channel, as well as adjust the scroll rate to 14 different speeds.

Ordering Information

Personal DaqView is included free with Personal Daq systems. More functionality can be added using the software options described on the next page.

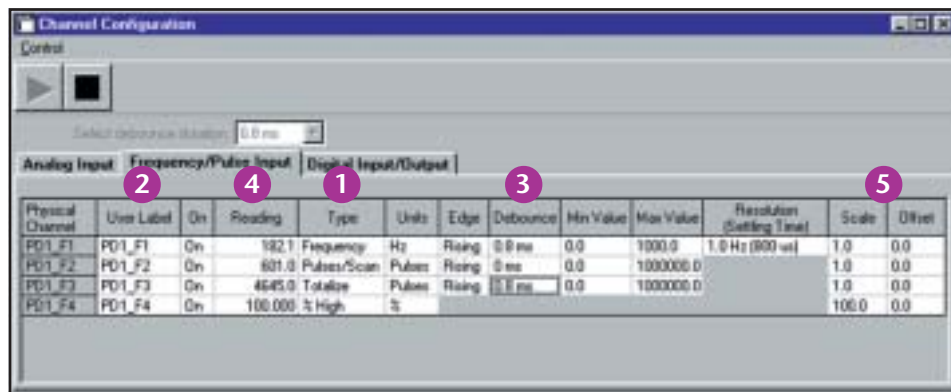

The Frequency/Pulse Input screen allows the user to:

- 1 Easily configure counter channels as frequency, pulse counting, totalized, or duty cycle inputs
- 2 View channels through both a physical channel description or a user-defined channel description
- 3 Set counter input signal debounce, input frequency range, and counter edge sensitivity on a per-channel basis
- 4 Display active or enabled frequency/counter channels in real time
- 5 Apply scale and offset values for real-time $mX+b$ operation

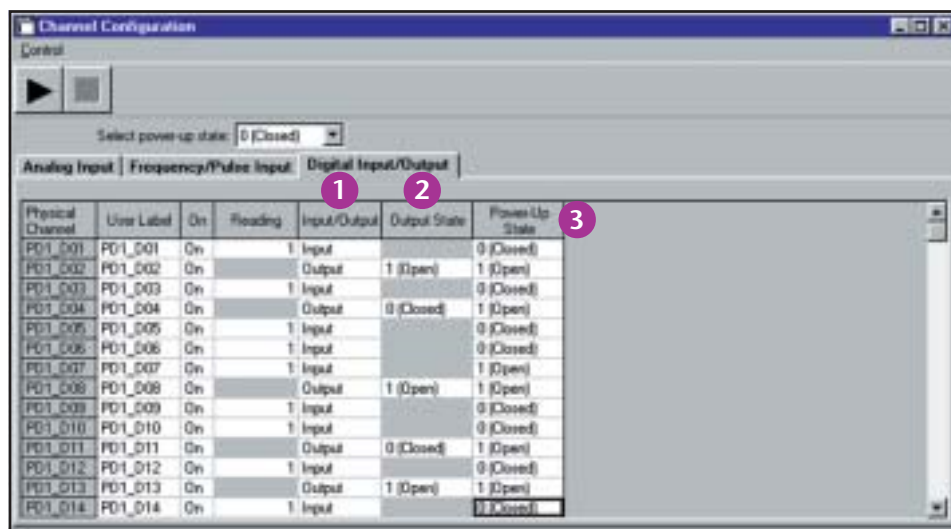

The Digital Input/Output screen allows the user to:

- 1 Read the current state of all digital input channels
- 2 Manually set the state of each digital output channel
- 3 Set the default power-up state for each digital output channel



Personal DaqView™

Out-of-the-Box™ Software Options

Personal DaqView Plus™

Optional Personal DaqView Plus software provides advanced charting capabilities, including multiple traces per chart, multiple chart groups, and support for up to 100 Personal Daq devices attached to one PC.

- Allows display groups to be created for customized viewing
- Supports up to 100 Personal Daq devices

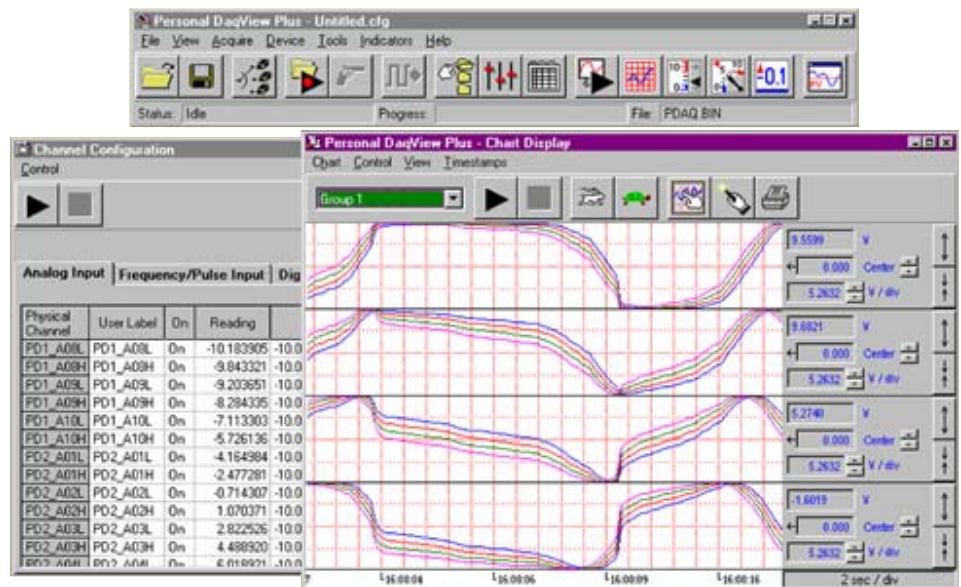

Personal DaqView Plus provides display of multiple channels in one chart

Personal DaqViewXL™

Optional Personal DaqViewXL software allows Personal DaqView or Personal DaqViewXL Plus to execute seamlessly from within Microsoft® Excel's tool palette. Acquired measurements are inserted directly into an Excel spreadsheet in real time.

- Allows formula creation on acquired data
- Provides control of acquisition from spreadsheet

Personal DaqViewXL Plus™

Optional Personal DaqViewXL Plus combines the features of Personal DaqView Plus and Personal DaqViewXL into one package.

Ordering Information

Description	Part No.
Spreadsheet-style software (included)	Personal DaqView
Enhanced functionality for Personal DaqView	Personal DaqView Plus
Microsoft Excel add-in for Personal DaqView	Personal DaqViewXL
Package combining the features of Personal DaqView Plus and Personal DaqView XL	Personal DaqViewXL Plus
Optional hardcopy Personal DaqView user's guide	491-0901

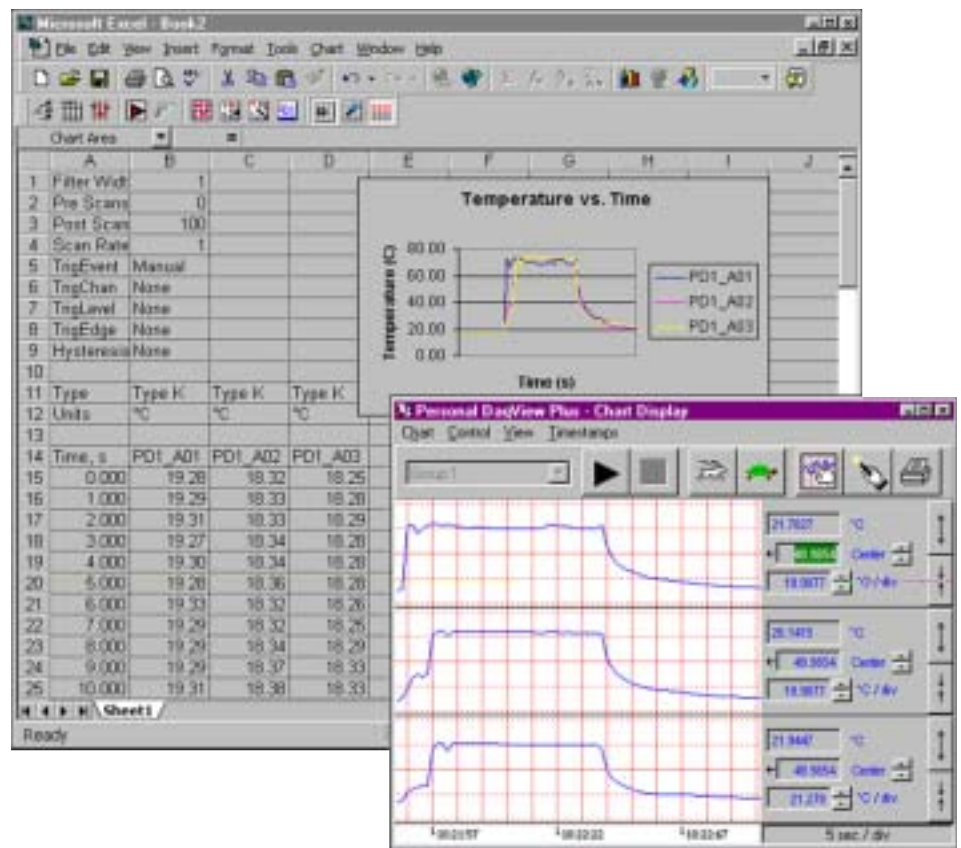

Personal DaqViewXL allows display of collected data with Excel and software package charts



Personal Daqs™

Specifications & Ordering Information

Specifications

General

Isolation: 500V from PC
Power Requirements: Powered from USB, or from an optional external +6 to +16 VDC when PC cannot provide adequate power
Environment: 0° to 50°C, 0 to 95% RH, non-condensing; relatively still air environment recommended for thermocouple measurements
AC Common Mode Rejection: >120 dB @ 50/60 Hz
Channel-to-Channel Crosstalk: <-110 dB (DC to 100 Hz; up to 10K Ohm source resistance)
Accuracy: 0.015% of reading, +0.002% of range (exclusive of noise)
Input Resistance: 10M Ohm (SE), 20M Ohm (DE)
Cold-Junction Accuracy: ±0.5°C (15° to 35°C)
Dimensions: 182 mm W x 92 mm D x 45 mm H (7.1" x 3.6" x 1.6")

Input Voltage Ranges	
Differential	Single-Ended
-20V to +20V	-10V to +20V
-10V to +10V	-10V to +10V
-5V to +5V	-5V to +5V
-4V to +4V	-4V to +4V
-2.5V to +2.5V	-2.5V to +2.5V
-2V to +2V	-2V to +2V
-1.25V to +1.25V	-1.25V to +1.25V
-1V to +1V	-1V to +1V
-625 mV to +625 mV	-625 mV to +625 mV
-500 mV to +500 mV	-500 mV to +500 mV
-312 mV to +312 mV	-312 mV to +312 mV
-250 mV to +250 mV	-250 mV to +250 mV
-156 mV to +156 mV	-156 mV to +156 mV
-125 mV to +125 mV	-125 mV to +125 mV
-62 mV to +62 mV	-62 mV to +62 mV
-31 mV to +31 mV	-31 mV to +31 mV

Analog Specifications

Each channel is configurable for single-ended or differential, volts, or thermocouple inputs
Personal Daq/55: 10 single-ended, 5 differential; volts or TC channels
Personal Daq/56: 20 single-ended, 10 differential; volts or TC channels
Input Voltage Range (software programmable on a per-channel basis)
Thermocouple Type: J, K, T, E, R, S, B, N14G, & N28G
Thermocouple Accuracy (°C)^{1,2}

TC Type	Temp Range (°C)	Accuracy (°C)
J	-100 to +700	±1.1
K	-200 to +1200	±1.2
T	-100 to +400	±1.1
E	-100 to +500	±1.0
R	+400 to +1400	±2.5
S	+400 to +1400	±2.6
B	+700 to +1400	±3.3
N	-100 to +700	±1.5

Over-Voltage Protection: ±45V relative to analog COM

Common Mode Rejection: 120 dB @ 60 Hz
Channel-to-Channel Crosstalk: 120 dB (0 to 100 Hz)

Gain Accuracy: 0.01% (after calibration, 15° to 35°C), 5 ppm/°C gain drift

1. Thermocouple accuracy includes cold junction compensation error
 2. Assume an acquisition speed of 610 ms per measurement

Speed vs Resolution*						
Speed Designation	Measurement Duration (Per Ch)	Maximum Aggregate Sample Rate				Resolution (Bits RMS) (-4V to +4V)
		Volts		Thermocouple		
		1-Channel Per Scan	10-Channels Per Scan**	1-Channel Per Scan	10-Channels Per Scan**	
Slowest, 50/60 Hz rejection	610 ms	1.1/s	1.6/s	1.1/s	1.6/s	22
Slow, 50 Hz rejection	370 ms	1.8/s	2.7/s	1.7/s	2.7/s	22
Slow, 60 Hz rejection	310 ms	2.1/s	3.3/s	2/s	3.2/s	22
Medium, 50 Hz rejection	130 ms	5.1/s	7.9/s	4.5/s	7.6/s	21
Medium, 60 Hz rejection	110 ms	6/s	9.3/s	5.2/s	9/s	21
Medium	40 ms	10/s	27/s	8.2/s	24/s	19
Fast	20 ms	13/s	53/s	9.7/s	42/s	17
Fastest	12.5 ms	14/s	78.1/s	10.3/s	57/s	15

* Each channel can have independent measurement duration and resolution
 ** These sample rates were obtained with continuous self-calibration disabled

Input Impedance: 10M Ohm (SE), 20M Ohm (DE)
Bias Current: <1nA (0° to 35°C)
Measurement Speed: Each channel can have a different measurement speed and resolution. Channels can be programmed to be scanned in any order.

Frequency Measurements

Personal Daq/55: 2 frequency/pulse input channels
Personal Daq/56: 4 frequency/pulse input channels
Operating Modes: Pulse count, totalize, duty-cycle, and frequency
Frequency Response: DC to 1 MHz
Input Range: ±15V, Schmitt-trigger inputs, <1.3V (low), >3.8V (high)
Pull-Up Resistor: 27K Ohm to +5V for switch or relay sensing
Debouncing: None, 0.8, 3.2, or 13 mSec.
Totalize: Up to 2³² counts/scan
Frequency & Duty-Cycle Resolution: 7 digits. Actual resolution depends on scan rate. At 10 scans/s, resolution is 5 digits (10 ppm); at 1 scan/s, 6 digits (1 ppm)

Digital I/O

Each I/O line is individually programmable as input or output.
Personal Daq/55: 8 digital I/O lines
Personal Daq/56: 16 digital I/O lines
 Each I/O line includes an open-collector driver with a 27K Ohm pull-up resistor to +5V for output, and a Schmitt-trigger input buffer
Over-Voltage: +20V for up to 1 minute
Input
Voltage Range: 0 to +15V
Thresholds: <1.3V (low), >3.8V (high)
Output
Voltage Range: 0 to +5V with no external pull-up resistor; 0 to +15V with external pull-up
Maximum Sink Current: 150 mA/output continuous, 500 mA output peak (<100 µs), 150 mA total continuous (per bank of 8 outputs)
Output Resistance: 10 Ohms max
Updates: Outputs may be changed arbitrarily at any time under program control.

PDQ11

Ports: 4
Power: 7.5 VDC @ 2 Amps
Dimensions: 140 mm W x 76 mm D x 25 mm H (5.5" x 3" x 1")

Ordering Information

Description	Part No.
22-bit data acquisition system including Personal DaqView™ and eZ-PostView™ software; support for Visual Basic®, C/C++, LabVIEW®, and DASyLab®	Personal Daq/55 Personal Daq/56
Bundled package with DASyLab	Personal Daq/55/DL Personal Daq/56/DL
Expansion module, with 20 volts/TC inputs and 16 digital I/O	PDQ1
Expansion module, with 40 volts/TC inputs	PDQ2
DIN-rail mounting adapter for Personal Daq	PDQ10
Powered 4-port USB hub with one USB cable	PDQ11
USB-powered extension cable, 16 ft.	PDQ12
PCI to dual USB card	PDQ13

Accessories & Cables

USB cable, 1 meter	CA-179-1
USB cable, 3 meters	CA-179-3
USB cable, 5 meters	CA-179-5
Terminal block	CN-153-12
Optional hardcopy Personal Daq user's manual	491-0901
External power supply	TR-2

Software

Enhanced functionality for Personal DaqView	Personal DaqView Plus
Microsoft® Excel add-in for Personal DaqView	Personal DaqViewXL
Package combining the features of Personal DaqView Plus™ and Personal DaqViewXL™	Personal DaqViewXL Plus
Icon-based data acquisition, graphics, control, & analysis with Personal Daq driver	DASyLab

Related Products

Software	
Personal DaqView	p. 228
DASyLab	p. 234
eZ-PostView	p. 239
eZ-TimeView	p. 240